



INSTALLATION INSTRUCTIONS

APPLICATION: COMPACT SIZE STANDARD BED TRUCK
INCLUDING TOYOTA TUNDRA
(FOR TUNDRA, ALSO USE #10-9900)

AUTOMOTIVE PRODUCTS, INC.

**BED X-TENDER
ASSEMBLIES**

10-0010

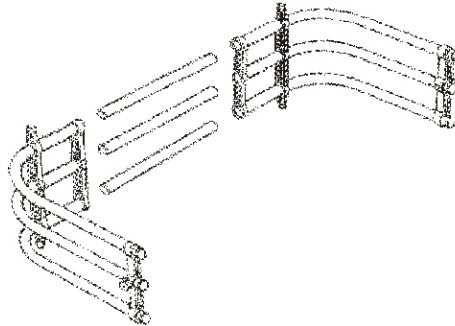

QTY	PART KIT CONTENTS DESCRIPTION	TOOLS REQUIRED
1	CURVED ASSY, DRIVER SIDE	10mm WRENCH
1	CURVED ASSY, PASSENGER SIDE	14mm WRENCH
3	CENTER TUBES	T-20 TORX WRENCH
2	SQUARE BRACKETS	PHILLIPS SCREW DRIVER
2	"L" BRACKETS	9/64" DRILL BIT
6	STANCHION ADJUSTMENT SCREWS (TORX HEAD)	7/32" DRILL BIT
6	SHEET METAL SCREWS (PHILLIPS HEAD)	DRILL
4	BOLTS (PHILLIPS HEAD)	
4	HEX NUTS	
6	LOCK WASHERS	
6	THIN WEDGES	
6	THICK WEDGES	

- STEP 1.** Remove the contents from the box and check for any damage. Verify all parts against the parts list. Read and understand instructions completely before beginning installation.
- STEP 2.** Position and hold template on passenger side for square bracket as shown (See Figure 1). (FOR TOYOTA, NISSAN, CHEVY S-10, GMC up to '94, and MAZDA up to '94 Use template for "L" bracket as shown in Figure 4). Using a center punch, punch each hole. **NOTE:** If the truck has a bed liner, center punch the bed liner. **DO NOT CUT THE BED LINER!** Repeat for driver side.
- STEP 3.** Verify hole locations before drilling (See Figure 2). Drill mounting holes for square brackets using 9/64" drill bit (See Figure 2). For "L" bracket mounting, drill mounting holes using 7/32" drill bit (See Figure 4). Repeat for driver side.
- STEP 4.** Mount passenger side square bracket using (3) phillips head sheet metal screws. (If the truck has a bed liner, mount square bracket on top of bed liner) (See Figure 3). For "L" bracket use, use (2) phillips head bolts, (2) lock washers and (2) hex nuts (See Figure 4). Repeat for driver side
- STEP 5.** Insert center tubes into each side of curved tubes as shown (See Figure 5). **NOTE:** For Flare Side trucks, cut 4" off each inside end of curved tubes to allow X-TENDER to fit within truck bed (See Figure 5).
- STEP 6.** Insert upright bosses into bed brackets. **NOTE:** X-TENDER must be vertical to allow bosses to fit into brackets (See Figure 6).
- STEP 7.** Adjust center tubes so that each side is inserted equally into each end of curved tubes (See Figure 5).
- STEP 8.** Install wedges into uprights. Install the thick wedges to the out side of the upright and the thin wedges to the inside as shown (See Figure 7). **NOTE:** Wedges fit flush against surface of uprights.
- STEP 9.** Insert stanchion adjustment torx head screws into uprights (one side only) and move center upright over curved tubes by tapping with rubber mallet (See Figure 7).
- STEP 10.** Push down on buckle to insert onto tailgate latch. To release, pull tailgate handle (See Figure 8). **NOTE:** It may be easier to insert buckle by first pushing latch inboard with buckle.

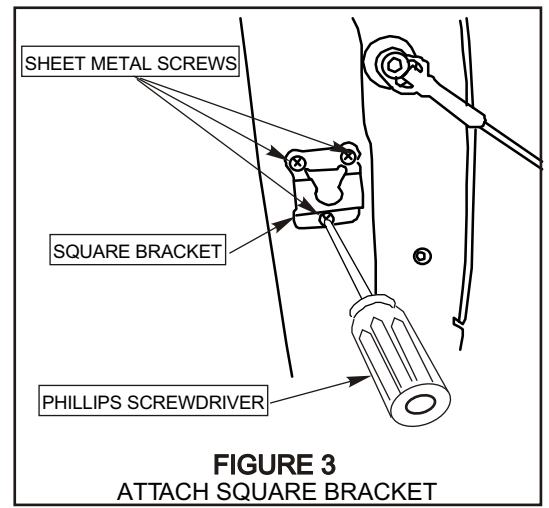
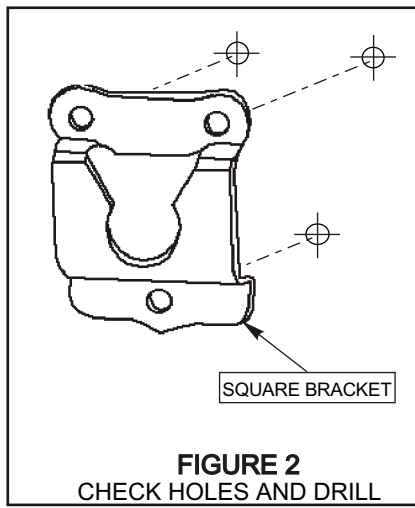
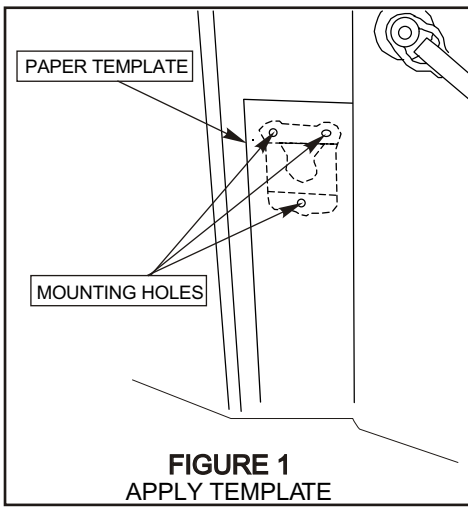

PASSENGER SIDE SHOWN, DRIVER SIDE OPPOSITE

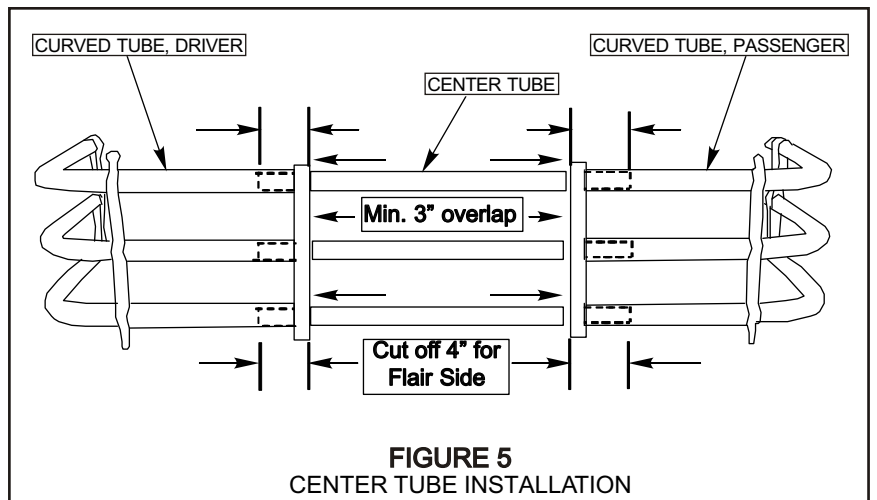
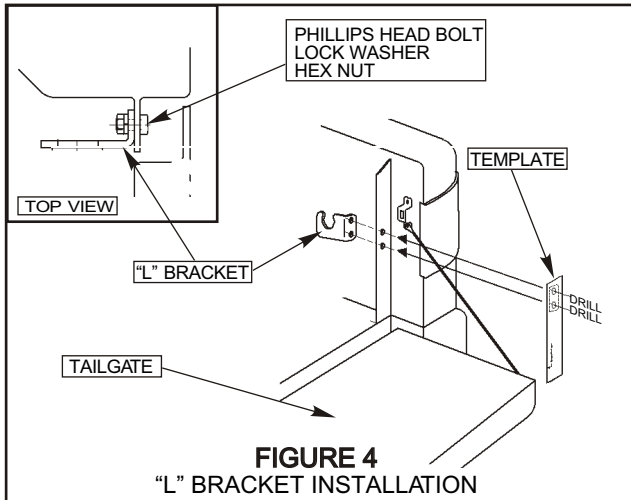

PASSENGER SIDE SHOWN, DRIVER SIDE OPPOSITE

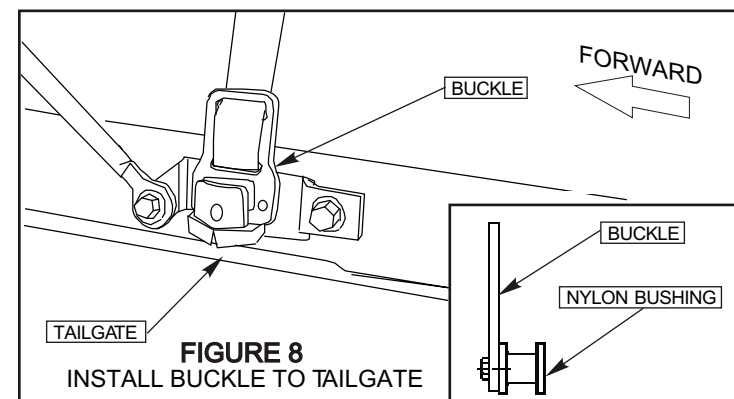
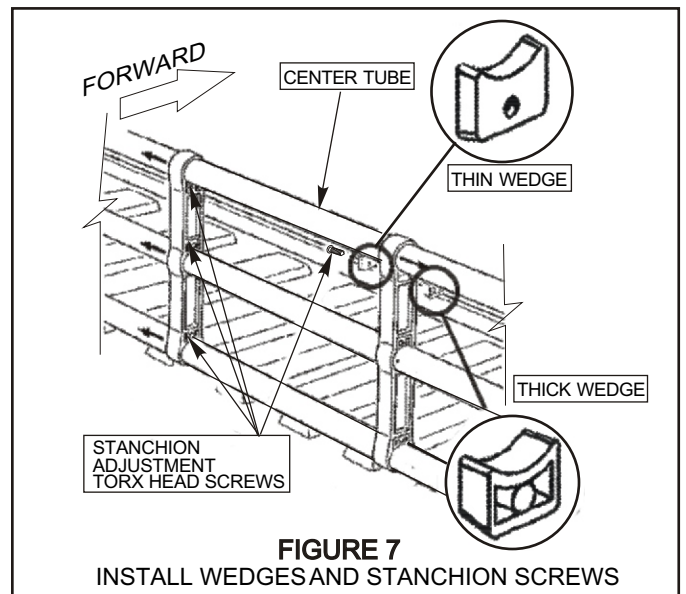
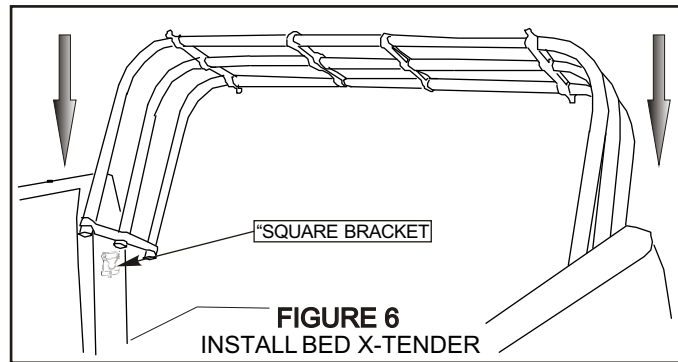

Tailgates with rotating latches (Toyota Tundra) require a nylon insert for each buckle. Note: For tailgates with slide-latches, nylon inserts must be removed from buckles.

DRIVER SIDE SHOWN, PASSENGER SIDE OPPOSITE

TEMPLATES

FOR TRUCKS WITH BEDLINERS, USE THIS TEMPLATE ON TOP OF THE BEDLINER.
DO NOT CUT THE BEDLINER!

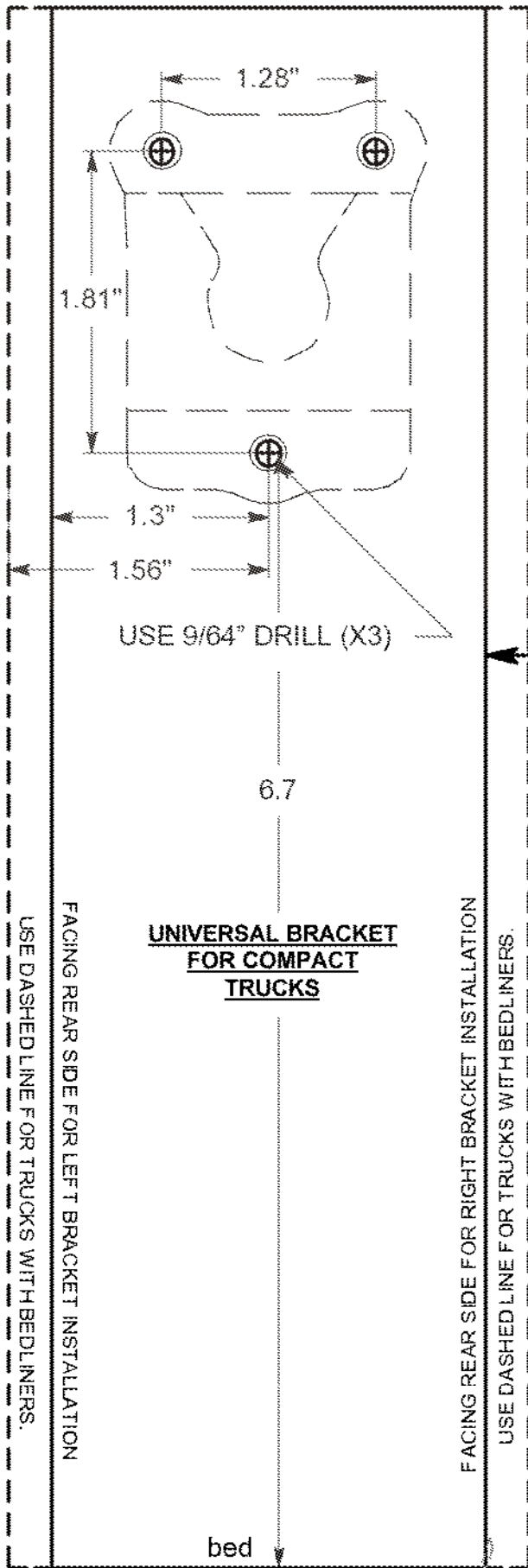

BRACKET INSTALLS ON TOP OF BEDLINER

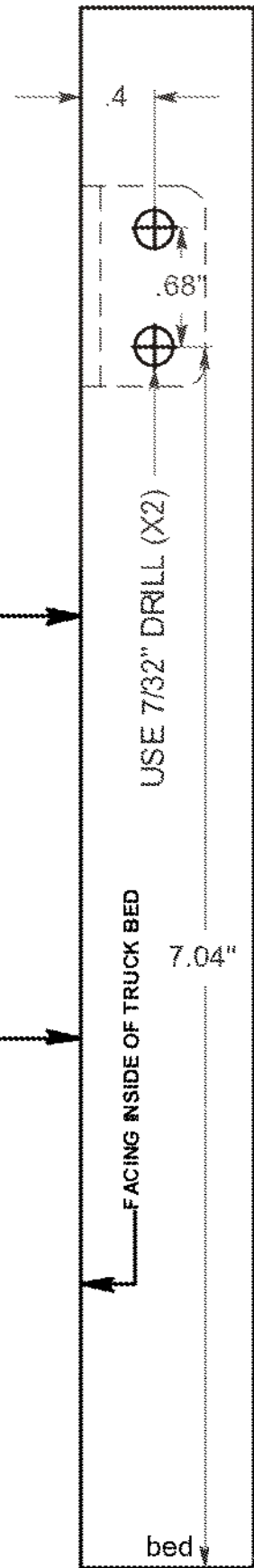
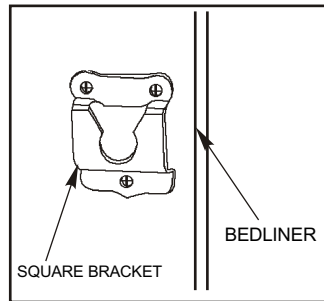



WESTIN

Premium Quality Truck Accessories

WESTIN WARRANTY AND DISCLAIMER

THREE YEAR WARRANTY

Westin Automotive Products, Inc. guarantees the original purchaser of Westin BED X-TENDERS a three-year warranty from the date of original purchase against manufacturer defects in materials, workmanship and finish under normal use excluding damage resulting from road hazards such as gravel or other debris, product misuse, improper installation, impairments from accidents, product modifications or product neglect. This three year warranty applies only to new products and is limited to the repair or replacement of Westin products. Warranty does not include costs of removal, installation, labor, inconvenience or consequential damages, This warranty is void if the carrying capacity exceeds 200 pounds, as clearly stated on the product warning label, affixed to the product.

Original purchaser must return defective merchandise, along with the purchase receipt, to the original place of purchase.

FINISH PROTECTION

Westin products have a high quality finish that must be cared for like any other exposed finish on the vehicle. Protect the finish with a non-abrasive automotive wax, (e.g. Pure Carnauba) on a regular basis. The use of any soap, polish or wax that contains an abrasive is detrimental, as the compounds scratch the finish and open it to corrosion.

DISCLAIMER FOR WESTIN PRODUCTS

Buyer assumes all risk and liability whatsoever from the installation and use of Westin products. Westin products are sold as decorative accessories and should not be relied upon as protection for the vehicle or occupants in the event of a collision or roll over. Vehicles equipped with a supplemental restraints system (air bags) deployed by impact should not be modified by any aftermarket Grille Guard, Push Bar, Light Bar or Bull Bar without first consulting the vehicle manufacturer. Westin Automotive Products, Inc. assumes no liability for injury, loss, incidental or consequential damages in the event of a collision or roll over.